



ESPECIFICACIONES



180x126x183cm



+1 año



30cm



10,2m²

DESCRIPCIÓN MATERIALES

Casita de juego para los más pequeños.

Estructura: madera tratada en autoclave.

Paneles: Polietileno de alta densidad (HDPE)

Tornillería: galvanizada en caliente.

Juego certificado según norma EN-1176

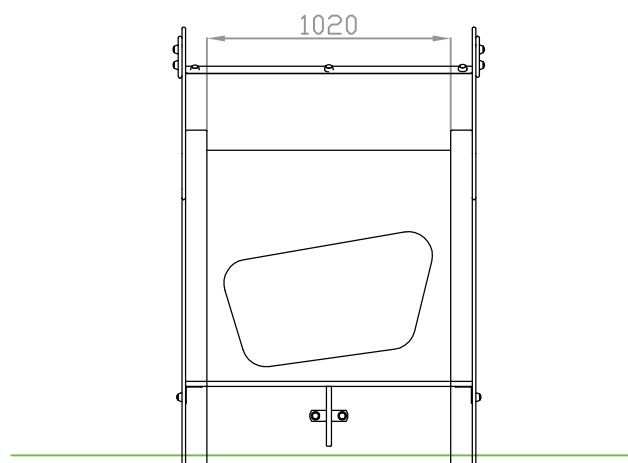
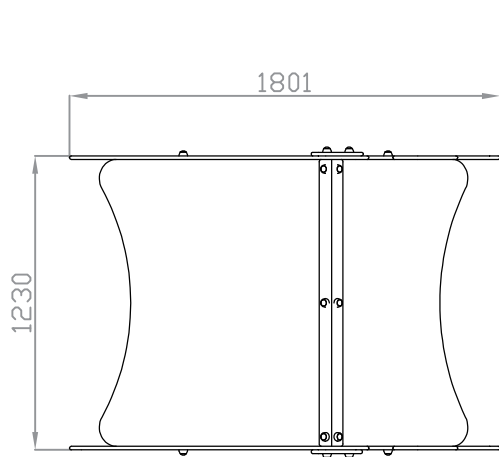
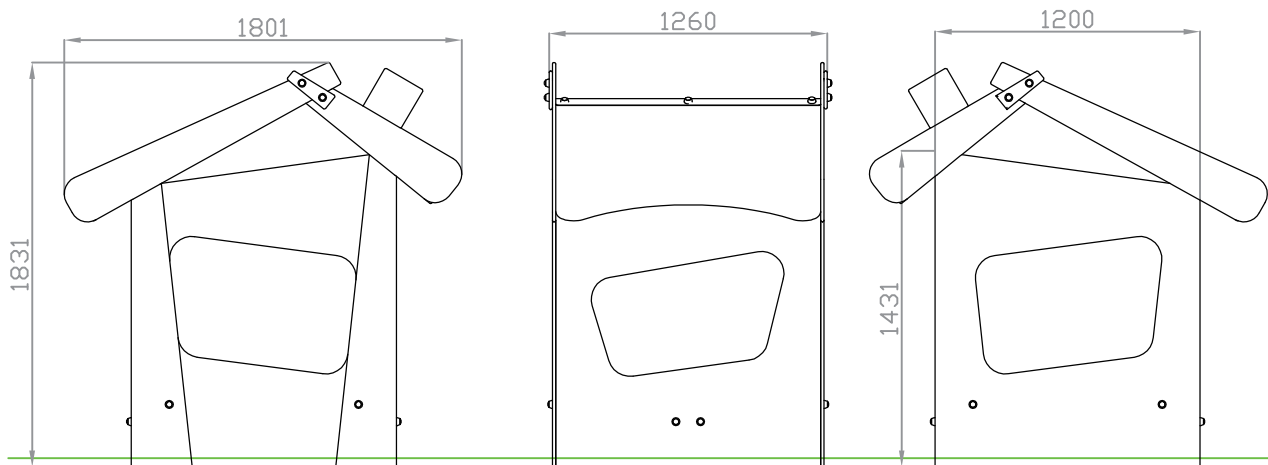

DETALLES CIMENTACIÓN

ESQUEMA DE CIMENTACIÓN EN ARENA

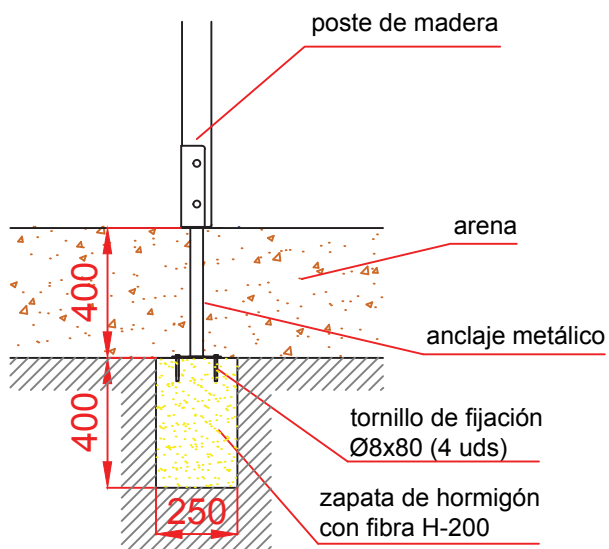

PLANTA CIMENTACIÓN

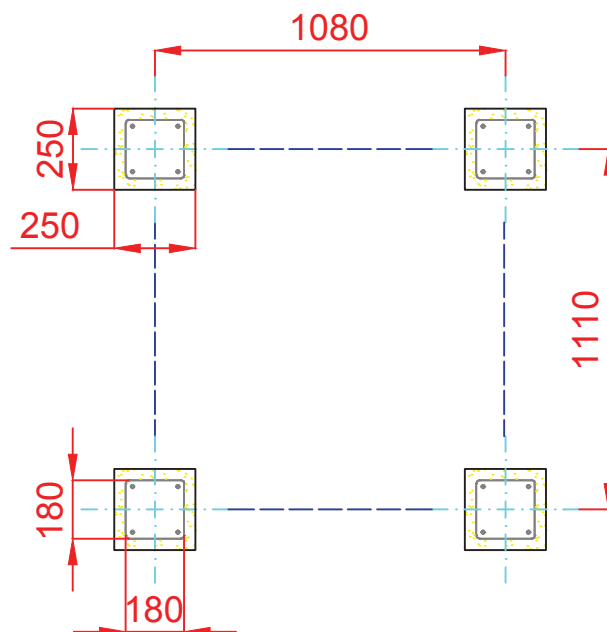

ESQUEMA DE CIMENTACIÓN EN HORMIGÓN

