

PARQUES INFANTILES

SERIE VILLA-RATÓN

REF: RTNMXT02-L
Conjunto
"Torre Mau"

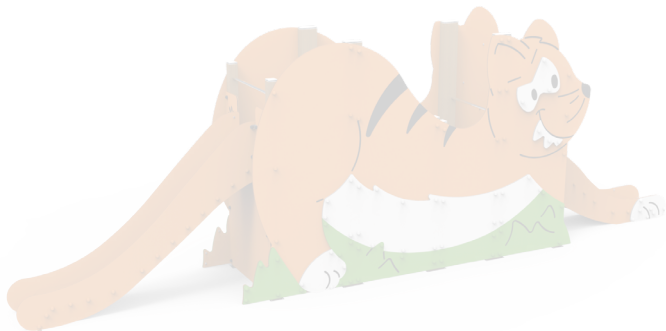

ESPECIFICACIONES



780x116x260cm.



+ 3 años



1,36m



4,2x9,4m

DESCRIPCIÓN MATERIALES

Conjunto que simula un camión de bomberos con diferentes paneles lúdicos y dos toboganes.

Estructura: madera de pino tratada en autoclave nivel IV.

Paneles y obstáculos: en polietileno de alta densidad (HDPE) con protección UV.

Tornillería: acero galvanizado con tapones de polipropileno.

Tobogán y barreras: acero inoxidable.

Juego certificado según normativa EN-1176

ALZADO

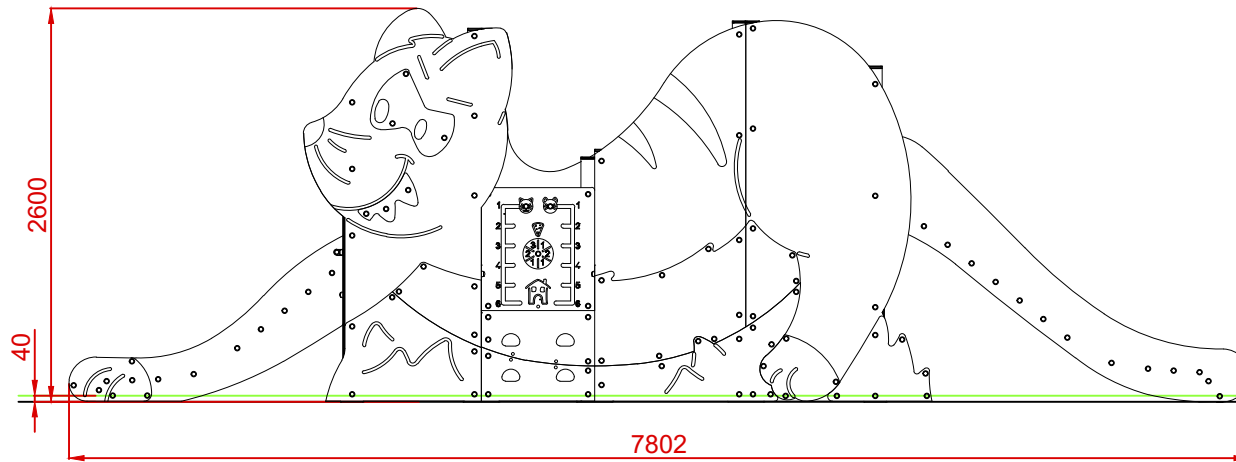

PERFIL

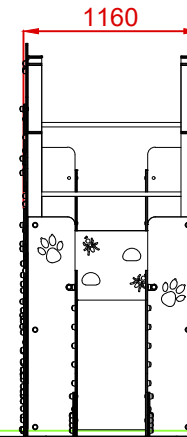

PLANTA

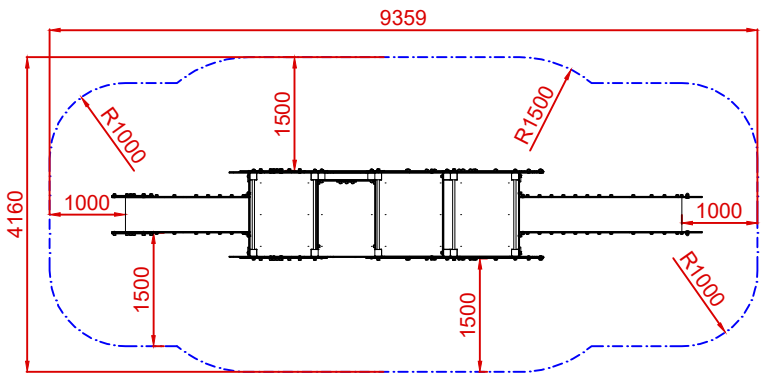
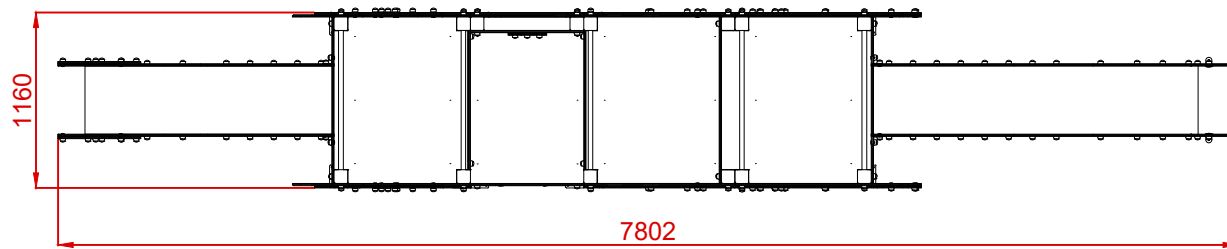

ÁREA DE SEGURIDAD
Superficie= 35,02 m²
E: 1/2

Dibujado		PLANO 1 VISTAS GENERALES	Ref:	RTNMXT02
Revisado				
Aprobado				
Descripción:	TORRE "MAU"	Escala: Fecha: 17/01/2022	Nº Hoja 2/3	

DETALLES CIMENTACIÓN

ESQUEMA DE CIMENTACIÓN EN ARENA

E: 2/1

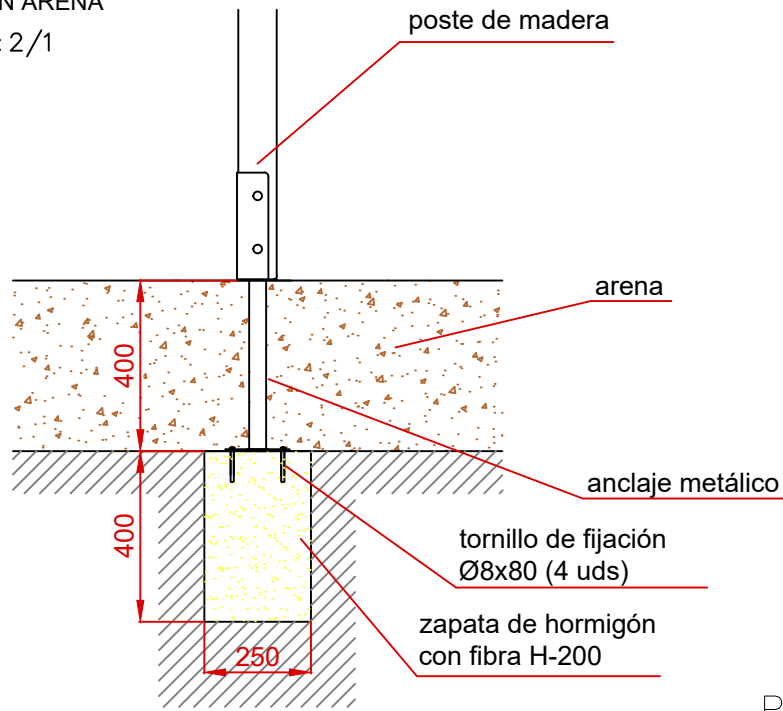

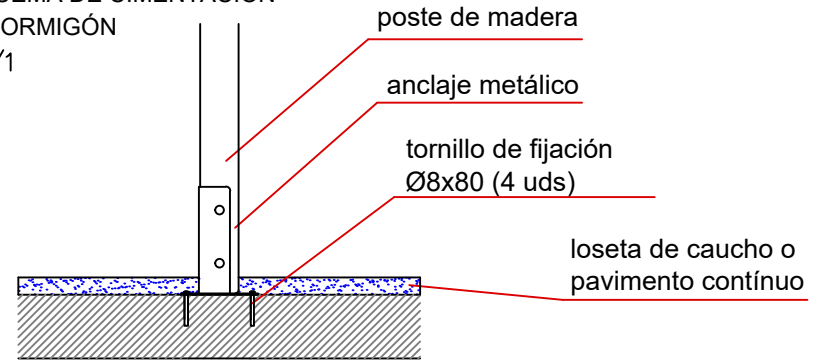

ESQUEMA DE CIMENTACIÓN EN HORMIGÓN

E: 2/1

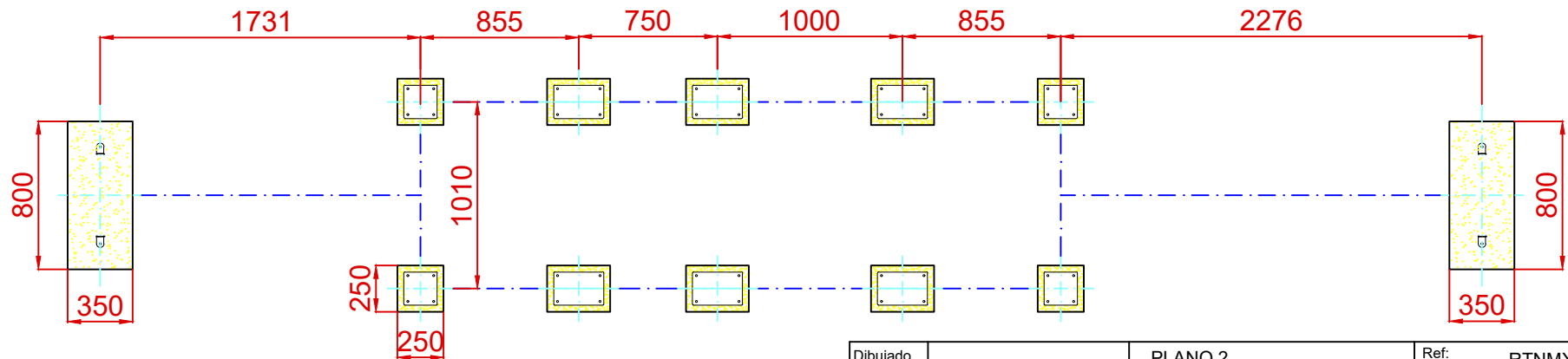

PLANTA CIMENTACIÓN



Dibujado		PLANO 2 CIMENTACIÓN Y ANCLAJES	Ref:	RTNMXT02
Revisado			 in.ser.urbana <small>INSTALACIONES Y SERVICIOS URBANOS</small>	
Aprobado				
Descripción:	TORRE "MAU"		Escala:	Nº Hoja 3/3
			Fecha:	17/01/2022