

# DOCUMENTACIÓN TÉCNICA



Ref.: MDVTBG01-L

Tobogán "Balagos"

UNE-EN 1176 -1:2018

UNE-EN 1176 -3:2018



Altura libre de caída: 1,36 m

Edad recomendada de uso: a partir de 3 años

Componentes plásticos: Polietileno de alta densidad con protección UV

Rampa de tobogán: acero inoxidable

Tubo superior: acero inoxidable

Tornillería protegida con tapones de polipropileno

ALZADO

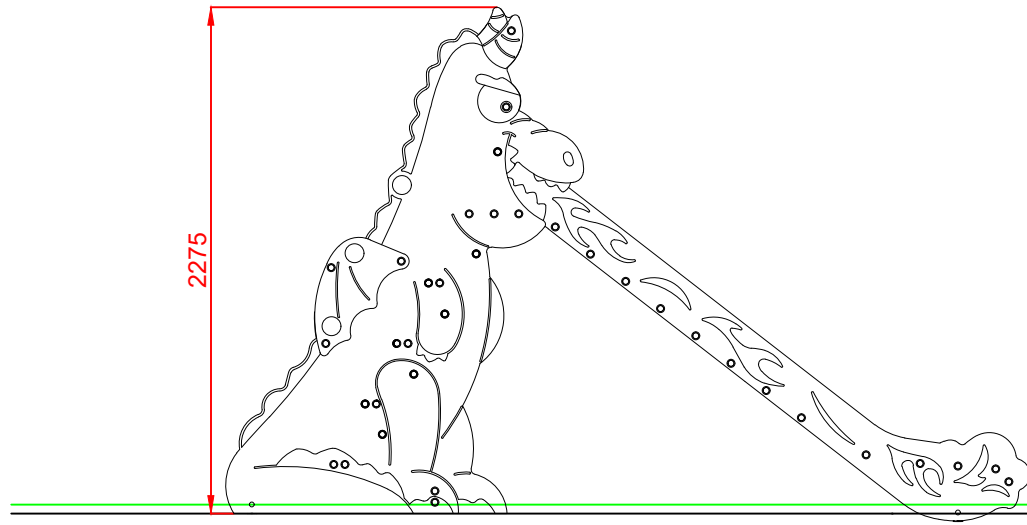

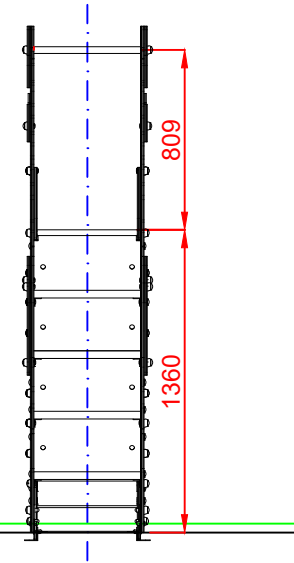

PERFIL

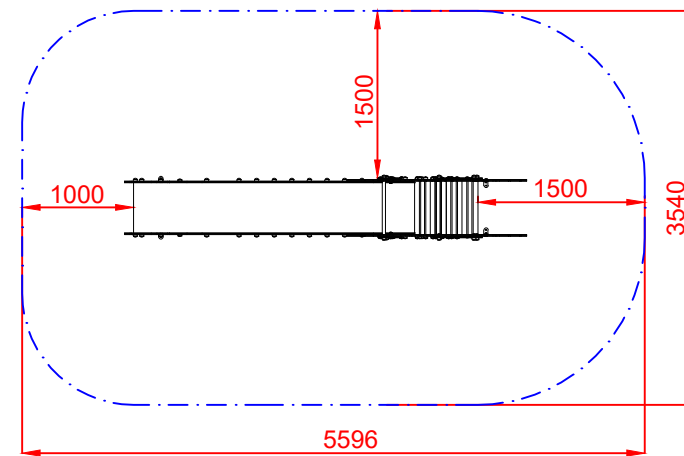
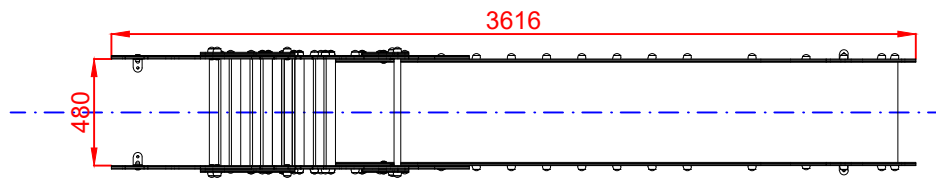

ÁREA DE SEGURIDAD  
Superficie= 18,42 m<sup>2</sup>  
E:1/2

PLANTA



Dibujado		PLANO 1 VISTAS GENERALES		Ref: MDVTBG01-L
Revisado				
Aprobado				
Descripción:	TOBOGÁN "BALAGOS"	Escala:	Nº Hoja 2/3	
		Fecha:	13/12/2021	

# DETALLES CIMENTACIÓN

ESQUEMA DE CIMENTACIÓN  
EN ARENA  
E: 2/1

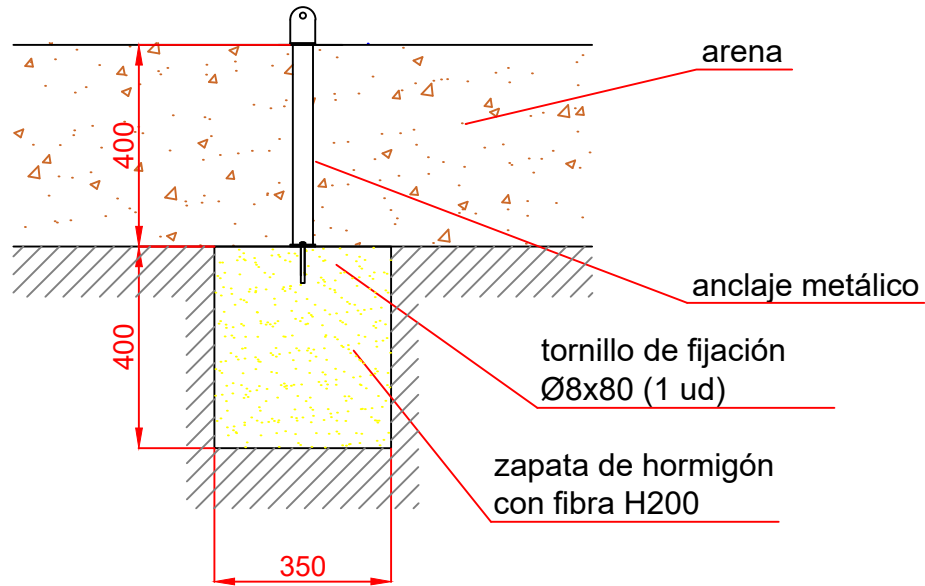

PLANTA CIMENTACIÓN

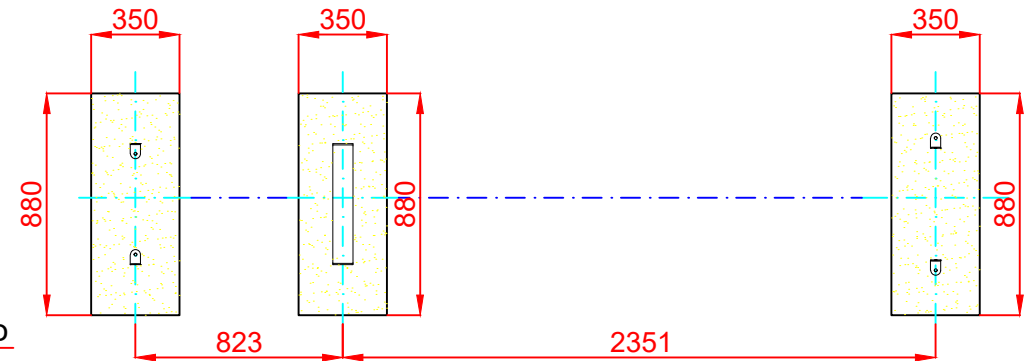

ESQUEMA DE CIMENTACIÓN  
EN HORMIGÓN  
E: 2/1

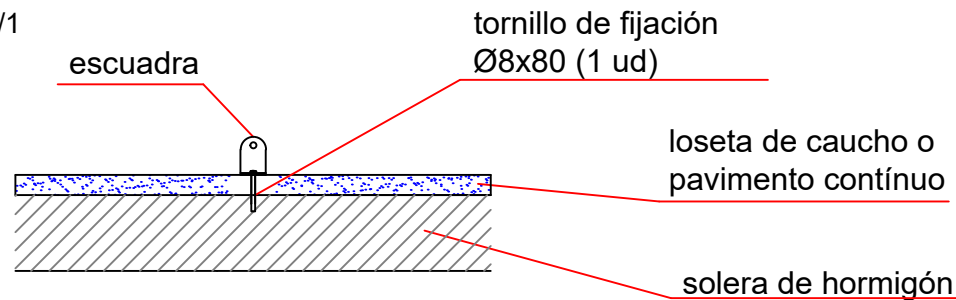

Dibujado		PLANO 2 CIMENTACIÓN Y ANCLAJES		Ref: MDVTBG01-L
Revisado				
Aprobado				
Descripción:	TOBOGÁN "BALAGOS"		Escala:	Nº Hoja 2/3
			Fecha:	13/12/2021