

PARQUES INFANTILES

SERIE ANIMALES

REF: 81014MOS
Hormiga



ESPECIFICACIONES



446x314x284cm.



+3años



130cm



7x6m

DESCRIPCIÓN MATERIALES

Estructura: acero inoxidable.

Paneles: polietileno de alta densidad (HDPE) disponible en varios colores reciclables.

Suelo con tablero fenólico antideslizante.

Tobogán: deslizador de acero inoxidable.

Trepa: red de cuerda con alma de acero.

Tornillería: acero inoxidable y protegida con cápsulas antivandálicas de poliamida.

Juego certificado según norma EN-1176

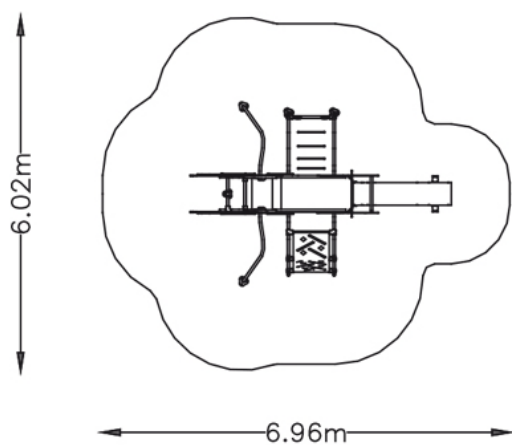
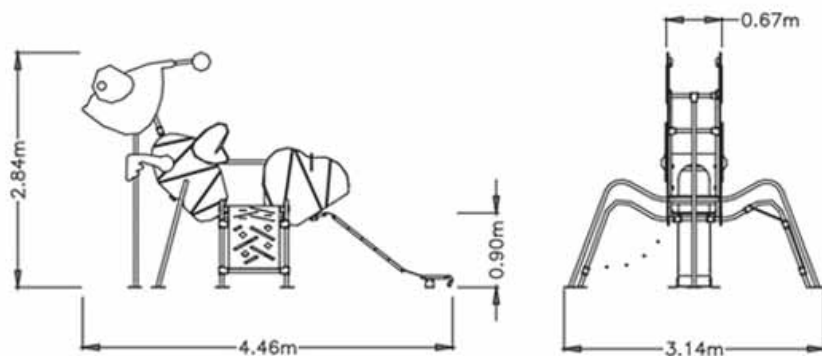

cotas en m.

